GENERAL NOTICE

NOTICE 57 OF 2011



INDEPENDENT COMMUNICATIONS AUTHORITY OF SOUTH AFRICA

**"IMPLEMENTATION OF THE ASYMMETRY PROVISIONS OF THE CALL
TERMINATION REGULATIONS (RELEASED IN GOVERNMENT GAZETTE
33698)**

I, Stephen Mncube, Chairperson of the Independent Communications Authority of South Africa hereby publish a Practice Note to all stakeholders entitled "Implementation of the Asymmetry Provisions of the Call Termination Regulations

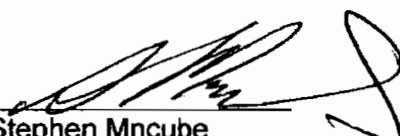
Dr Stephen Mncube
Chairperson



Independent Communications Authority of South Africa

Pinmill Farm, 164 Katherine Street, Sandton
Private Bag X10002, Sandton, 2146

**PRACTICE NOTE ON THE IMPLEMENTATION OF THE ASYMMETRY PROVISIONS OF
THE CALL TERMINATION REGULATIONS**

Date of issue: 28 January 2010

1. Purpose

1.1. The purpose of this practice note is to provide clarity to stakeholders on the asymmetry provisions of Appendix B of the Call Terminations released on the 29th of October 2010 in Government Gazette No. 33698.

1.2. The specific areas to be clarified are:

- 1.2.1. What market is the licensee in?
- 1.2.2. What is Within Billing Zone and Beyond Billing Zone?
- 1.2.3. Is it possible to charge different wholesale call termination rates to different licensees?
- 1.2.4. How does a licensee qualify for asymmetry under the provisions of Appendix B of the regulations?
- 1.2.5. Can the right to charge an asymmetric rate be revoked?
- 1.2.6. What is the maximum allowable rate which a licensee may charge?
- 1.2.7. Is the Community Service Telephone wholesale voice call termination rate still applicable?

2. What market is the licensee in?

2.1. The Authority has defined two markets:

- 2.1.1. Market 1: The market for wholesale voice call termination services to a mobile location on the network of each licensee who offers such a service within the Republic; and
- 2.1.2. Market 2: The market for wholesale voice call termination services to a fixed location on the network of each licensee who offers such a service within the Republic, consisting of:
 - 2.1.2.1. The market segment for wholesale voice call termination to a fixed location within an 0N geographic area code; and
 - 2.1.2.2. The market segment for wholesale voice call termination to a fixed location between 0N geographic area codes.

2.2. Market 1 consists of an ECNS or ECS licensee providing a wholesale call termination service to mobile subscriber equipment enabled by wireless technology. This service allows a subscriber to initiate/receive and continue a voice call for the duration of that call, despite any change in location, i.e. complete handover.

2.3. Market 2 consists of an ECNS or ECS licensee providing a wholesale voice call termination service provided to a fixed location, and includes call termination using fixed wireless services. This service requires a subscriber to remain at a specific geographic location for the duration of the call, or within a specific geographic boundary in the case of fixed wireless services, i.e. it is not possible for the subscriber to initiate/receive and continue a voice call during the call.

2.4. Any licensee who cannot offer full call handover as a retail service to subscribers therefore falls under the definition for Market 2.

3. How to interpret "Within ON code" and "Between ON code"

3.1. The Authority defined "ON" as a "geographic area code as specified in Regulation 6 of the Numbering Plan Regulations"¹

3.2. The geographic area codes in Regulations 6 of the Numbering Plan regulations is reproduced below:

Geographic Area Code	Geographic Region
01	Gauteng, Limpopo, North west Province and Mpumalanga
02	Parts of Western Cape
03	KwaZulu – Natal and parts of Eastern Cape
04	Eastern Cape and parts of Western Cape
05	Free State and Northern Cape

Figure 1: Geographic area codes assigned to fixed location services²

3.3. There are three scenarios to be considered in establishing which rate to apply for wholesale fixed call termination to a fixed location.

¹ Definitions section of the Call Termination regulations, GG 33698.

² Regulation 6 of Numbering Plan Regulations, GG 28839.

3.3.1. Scenario 1: Subscriber A on Licensee A's network calls Subscriber B on Licensee B's network. The subscribers are in the same geographic regions according to the geographic area code. The transfer of traffic between licensees (termination) takes place over a point of interconnection within the same geographic area code as assigned to Subscriber B. The "Within ON code" wholesale call termination rate applies. See Figure 1.

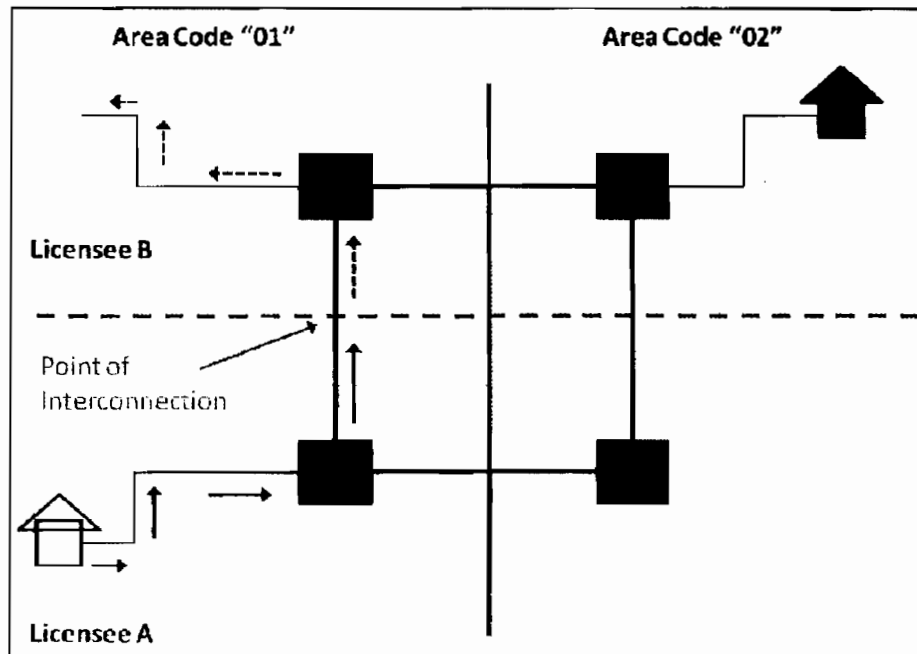

Figure 1. Within ON Area code termination: subscribers and point of interconnection in the same geographic area

3.3.2. Scenario 2: Subscriber A on Licensee A's network calls Subscriber B on Licensee B's network. The subscribers are in different geographic regions according to the geographic area code. The transfer of traffic between licensees (termination) takes place over a point of interconnection in the same geographic area code that is assigned to Subscriber B. Again, the "Within ON code" wholesale call termination rate applies. See Figure 2.

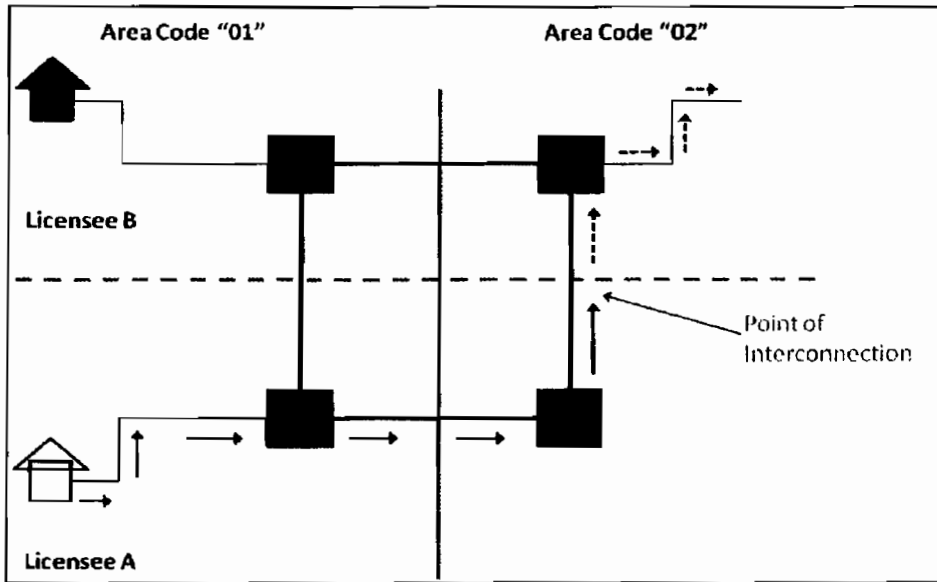

Figure 2. Within ON Area code termination: point of interconnection is in the same geographic area code as the receiver of the call

3.3.3. Subscriber A on Licensee A's network calls Subscriber B on Licensee B's network. The subscribers are in different geographic regions according to the geographic area code. The transfer of traffic between licensees (termination) takes place over a point of interconnection in the same geographic area code that is assigned to Subscriber A. The "Between ON" wholesale call termination rate applies. See Figure 3.

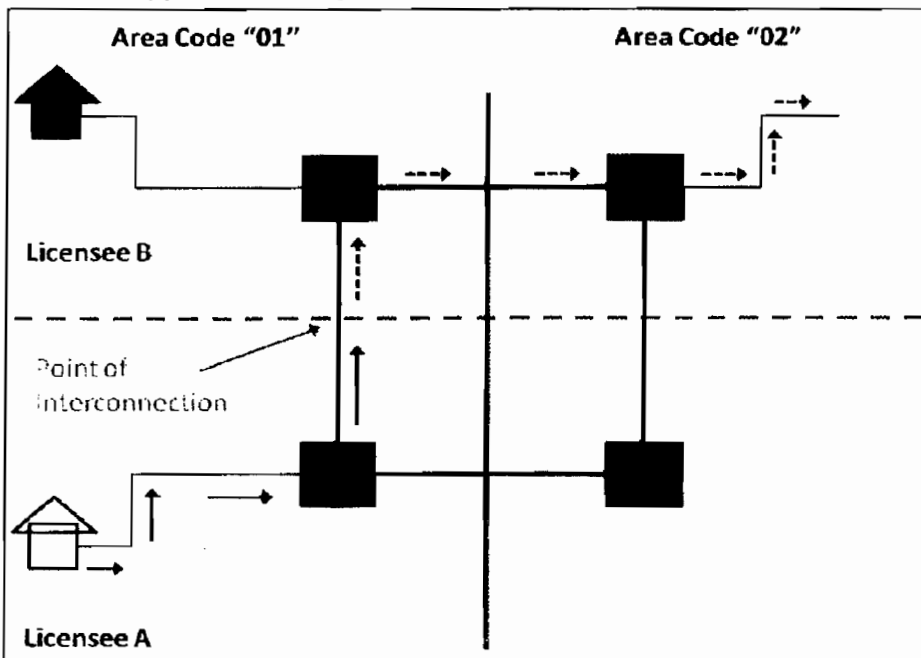

Figure 3. Between ON area codes termination: point of interconnection is in the same geographic area code as the originator of the call

3.4. Charging for wholesale voice call termination to a fixed location to a non-geographic number: The applicable wholesale call termination rate should be determined by licensees through commercial negotiation. The termination rate applicable to non-geographic numbers cannot be higher than the rate established for "Beyond ON area code" and is expected to be lower, based on traffic flow analysis and agreement between licensees.

4. Is it possible for a licensee to charge different wholesale call termination rates to different licensees?

4.1. Based on the finding that all licensees have significant market in the market in which they operate, every licensee is subject to the non-discrimination provisions of the Interconnection Regulations (GG 33101) and specifically Regulations 10(3) which states that:

An interconnection provider must apply similar terms and conditions, including those relating to rates and charges, in similar circumstances to itself, affiliates and other interconnection seekers, providing similar services, unless otherwise requested by the interconnecting party.

4.2. Practical interpretation of Regulation 10(3) of the Interconnection Regulations given the finding that all licensees have significant market power means that a licensee may charge one wholesale call termination rate per market in which the licensee participates.

4.3. The wholesale call termination rate which a licensee charges is not based on the source of interconnecting traffic but on the destination for the interconnecting traffic, i.e. wholesale voice call termination to a mobile or fixed location.

5. How does a licensee qualify for asymmetry under the provisions of Appendix B of the regulations?

5.1. No licensee has an automatic right to charge an asymmetric wholesale call termination rate. The conditions under which a licensee may charge an asymmetric wholesale call termination rate are clearly stipulated in Appendix B of the Call Termination regulations. Licensees not required to comply with the price control are able to charge a (higher) termination rate based on the following factors:

5.1.1. Spectrum allocation: A licensee must justify why it is adversely affected by current spectrum allocation; and/or

- 5.1.2. Economies of scale and scope based on the share of total minutes terminated in the relevant market: A licensee qualifies for an asymmetric rate if it has less than 25 per cent of total terminated minutes in the relevant market as of June 2009.
- 5.2. Appendix B of the regulations state that any licensee who may show it has been adversely affected by current spectrum allocations may offer an asymmetric termination rate. It is up to a licensee concerned to prove to the Authority that it deserves an asymmetric wholesale call termination rate based on spectrum allocation. The Authority will address such matters on a case-by-case basis.
- 5.3. However, another way the same licensee may qualify for an asymmetric termination rate is if the licensee has a share of less than 25% of total terminated minutes in the relevant market as of June 2009.
- 5.4. The relevant market in this case is the total number of minutes terminated in the relevant retail market, i.e. total minutes terminated to either a mobile or a fixed location as indicated in Tables 2.3 and Table 2.4 on pages 55 and 56 of GG 33121.
- 5.5. The shares of total terminated minutes in relation to the relevant markets using this metric are illustrated in Table 1 below:

Table 1: Licensee share of total terminated minutes as of June 2009³

Market 1: Termination to a mobile location	
Licensee	Percentage share
Licensee 1	43%
Licensee 2	42%
Licensee 3	14%
Market 2: Termination to a fixed location	
Licensee name	Percentage share
Licensee 1	98%
All other fixed licensees	2%

5.6. Table 1 above indicates that, for now:

- 5.6.1. All licensees other than MTN and Vodacom are entitled to charge an asymmetric wholesale call termination rate for termination to a mobile location

³ Sourced from industry submissions to the Call Termination questionnaire released in 2009.

5.6.2. All licensees other than Telkom are entitled to charge an asymmetric wholesale call termination for termination to a fixed location

6. Can the right to charge an asymmetric rate be revoked?

6.1.A licensee may lose the right to charge an asymmetric wholesale call termination rate if it achieves a share of equal to or greater than 25% per cent of total terminated minutes in the respective market.

6.2.All licensees are obliged to submit the relevant information to the Authority under Regulation 7(2)(b) of the Call Termination regulations by submitting requested information under the soon-to-be completed Compliance Manual regulations.

6.3.The Authority will make a determination as to whether certain licensees may continue to charge an asymmetric wholesale voice call termination rate based on the outcome of the analysis of industry submissions.

6.4.No licensee may lay a retrospective claim on another licensee that has gained a share of total terminated minutes in the respective market during a particular year of the glide-path.

7. What is the maximum allowable rate which a licensee may charge?

7.1.To ensure efficient pricing, the Authority has capped and reduced the asymmetric rate which a licensee may charge over time. Table 2 below indicates the allowable maximum percentage above the cost-oriented rate a licensee may charge.

Table 2: The cap on non-regulated wholesale call termination rates

	Maximum percentage above rate set for identified licensees
Current	-
01-Mar-11	20%
01-Mar-12	15%
01-Mar-13	10%

7.2.The maximum allowable wholesale voice call termination rate is to be calculated using the following formula:

$$\text{Max rate} = \text{Regulated rate} \times (1 + \% \text{ allowance})$$

Where:

- Max rate = the maximum wholesale voice call termination rate a licensee may charge
- Regulated rate = the set rate, per market for each of the three years of the glidepath as specified in Regulation 7(5)(b) of the Call Termination Regulations
- % allowance = the maximum percentage above rate set for identified for licensees as specified paragraph 2 of Annexure B of the Call Termination Regulations

7.3. Tables 3 and 4 below indicate the maximum wholesale voice call termination rate a licensee may charge under the asymmetry conditions in the regulations, per market.

Table 3: Maximum allowable asymmetric rate in Market 1: Termination to a mobile location

	Asymmetric allowance	Regulated rate		Max allowable termination rate	
		Peak	Off-peak	Peak	Off-peak
01-Mar-11	20%	R 0.73	R 0.65	R 0.88	R 0.78
01-Mar-12	15%	R 0.56	R 0.52	R 0.64	R 0.60
01-Mar-13	10%	R 0.40	R 0.40	R 0.44	R 0.44

Table 4: Maximum allowable asymmetric rate in Market 2: Termination to a fixed location

	Asymmetric allowance	Within ON area code				Between ON area code			
		Regulated rate		Max allowable asymmetric rate		Regulated rate		Max allowable asymmetric rate	
		Peak	Off-peak	Peak	Off-peak	Peak	Off-peak	Peak	Off-peak
01-Mar-11	20%	R 0.20	R 0.12	R 0.24	R 0.14	R 0.28	R 0.19	R 0.34	R 0.23
01-Mar-12	15%	R 0.15	R 0.12	R 0.17	R 0.14	R 0.25	R 0.19	R 0.29	R 0.22
01-Mar-13	10%	R 0.12	R 0.12	R 0.13	R 0.13	R 0.19	R 0.19	R 0.21	R 0.21

7.4. The Authority would like all licensees to note that the Authority has no intention of determining wholesale call termination rates per licensee. Licensees who qualify to charge an asymmetric wholesale call termination rate may charge a rate up to the maximum specified rate per market, whilst ensuring compliance with the non-discrimination provisions of the Interconnection Regulations.

8. Is the Community Service Telephone wholesale voice call termination rate still applicable?

8.1. The obligation to provide Community Service Telephones (CSTs) continues into the licensing regime of the ECA, with MTN, Cell C and Vodacom being obliged to maintain their Universal Service Obligations (USO's).
